

A NEW SOLUTION TO  
AN OLD  
PROBLEM

A new innovative, low cost design for a power factor corrected power supply. It requires no special integrated circuits or components. The high degree of correction is independent of input frequency or waveform, and is universal input capable. Bring power factor correction to many applications with minimal cost.

David A. Kelly  
[davidk@stonepathelectronics.com](mailto:davidk@stonepathelectronics.com)  
<http://www.stonepathelectronics.com>

17 August 2000

Revision 1.11

Copyright © July 2000 all rights reserved

## **Background**

The constant growth in the number of DC powered devices operated from the AC mains has increased the need to bring power factor correction to devices operating at a lower power level. However, power factor correction of low power devices threatens to increase the cost of consumer electronics.

## **Benefits Offered by This New Technology**

The above issue offers an opportunity for a new technology to provide a competitive advantage to manufacturers who utilize it in their consumer electronic equipment. The cost advantage over their competition can result in either increased market share or improved profit margins.

The proprietary technology described in two patent applications, the first recently allowed, will be briefly described with test results from working proto-types. These new techniques will allow licensed manufacturers to incorporate power factor correction in their products at a lower cost than conventional methods. The licensees of this technology will be able to offer these “green or more environmentally friendly” type of products with minimal increased cost. Those corporations who do not have rights to this technology will have to use the more expensive traditional approaches.

## **Proposed Technology**

The following technology is covered by Canadian patent application S.N. 2,298,428 which is currently open for public inspection and for which notice of allowance has been received. Aspects of the technology relating to use of the technology in creating a universal input capable power supply where all outputs would be well-regulated and low ripple are covered by a second pending Canadian patent application S.N. 2,306,438.

United States and international patent rights have been preserved for both applications.

The technology is based on a recognition that the fly-back power supply technology, see figure 1 and the associated technical theory section can be modified to achieve a high degree of Power Factor correction as well as a regulated output with electrical isolation, a requirement for most consumer products. In its simplest form the power correction circuit can be used for charging batteries. Alternately it can be used as an AC adapter and through use of an appropriately sized filter capacitor as a regulated power supply. Multiple outputs are created through the use of multiple secondaries, the same as with a standard fly-back power supply. This technology can be used as the power supply in a TV or VCR, radio etc. The technology is almost cost neutral as the primary capacitor is deleted as well as any inrush-

limiting component. The secondary capacitance may be increased to reduce the ripple that may be present. The primary control circuit uses feedback from the secondary in a similar manner used in the traditional fly-back design. The design may have to use a more traditional power factor control integrated circuit if the fly-back transformer is allowed to operate substantially in the continuous mode.

By incorporating a second fly-back transformer a power supply with very high power factor, using a single switch is possible, see figure 2. A single power supply control integrated circuit such as the inexpensive UC3844 is all that is required. An expensive power factor correction integrated circuit and its associated components is not required! With only a single switch and a single control circuit a high quality power factor can be achieved that is independent of the input voltage waveform. Universal input designs do not degrade the performance. This design does not suffer the problems that plague other single switch designs.

## **Technical Theory**

Referring to figure 1 the implementation of the invention is simple and is based on the fly-back power supply topology. Item 4 is the input AC voltage rectified by 6 into a pulsating DC 7. This pulsating DC is then applied to the primary 10 of a fly-back transformer and switch 14, without filtering, though filtering to reduce switching noise is assumed. The switch then opens and closes at a duty set by the control circuit 18. A feedback 29 provides an input to the control 18 to regulate the power applied to a battery 30, which could also be an electronic device that uses dc power. Not shown in this simple drawing is an output filter though it is assumed to be present.

Referring to Figure 1, when switch 14 closes a current is induced in the primary 10 of the transformer. This current is given by the equation

$$I_p = V_{in} * D / F \text{ equation 1}$$

Where

\* means multiply

/ means divide

D/F = Ton, the ON time of the Switch 14

I<sub>p</sub> (ampere) is the current in primary 10, prior to the opening of switch 14.

V<sub>in</sub> (volts) is the input voltage 7 at time switch 14 closes

D is the duty of the switch, a ratio of time on to the total of time on and off

F (hertz) is the frequency of closing and opening of switch 14

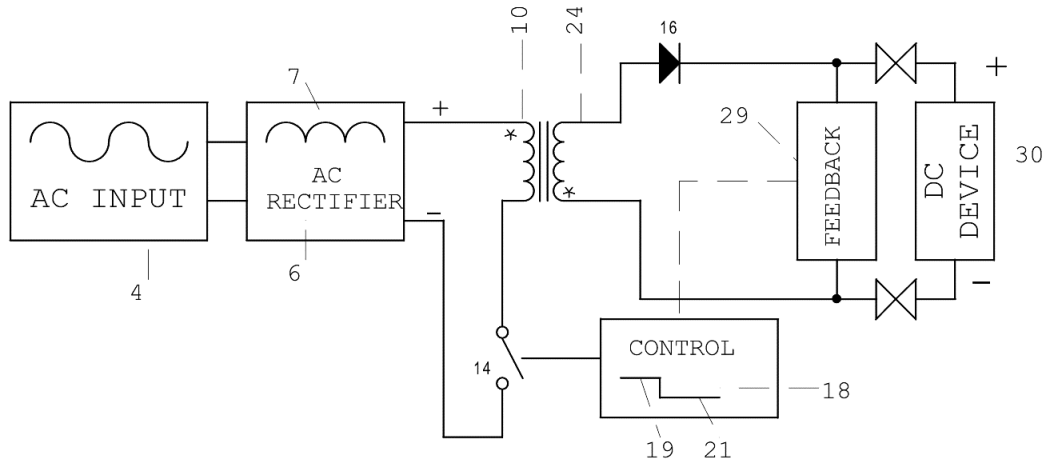

FIGURE 1

When the switch 14 opens the energy stored in the magnetic field will transfer from the primary 10 to the secondary 24 where diode 16 passes it to the load, in this example a dc device or battery 30.

The energy stored in the magnetic field of primary 10 is given by the equation.

$$E = \frac{I_p * I_p * L}{2} \text{ equation 2}$$

where

E is energy in joules stored in the magnetic field of the primary 10

L (henries) is the inductance of primary 10

I<sub>p</sub> (amps.) is the current in primary 10, prior to opening switch 14

By substituting from 1 into 2 and reducing the equation you get.

$$E = \frac{V_{in} * V_{in} * D * D * L}{2 * F * F} \text{ equation 3}$$

where all variables have been previously explained

The output power transferred to the secondary is expressed by the equation

$$P_{out} = E * F \text{ equation 4}$$

Where

P<sub>out</sub> (watts) is the power delivered to the load in this case battery 30

By substituting 3 into 4 you get

$$P_{out} = \frac{V_{in} * V_{in} * D * D * L}{2 * F} \quad \text{equation 5}$$

this then becomes

$$P_{out} = V_{in} * V_{in} * \text{Constant} \quad \text{equation 6}$$

where

$$\text{Constant} = \frac{D * D * L}{2 * F} \quad \text{which is analogous to} \quad \frac{1}{\text{Resistance}}$$

If  $V_{in}$  is expressed in rms then you get the equation (6) for power used by a resistive load. The power delivered by this circuit is the same as if it was a resistive or unity power factor load. By keeping all the terms other than  $V_{in}$  more or less constant the power delivered to the output load, in this case a dc device or battery 30 will appear as resistive, regardless of its true nature. The current into the dc device or battery will of course not be pure dc but a pulsating dc and will be a function of the input voltage  $V_{in}$ . If necessary a filter circuit can be used to provide a low ripple dc voltage.

## **Special Application; Well Regulated DC Output**

Figure 2 shows a special application where a second switch-mode power supply, right of line A-B, has been added after the power factor correction circuit, left of line A-B, to provide a low ripple well regulated dc output. It is new over prior art in that the switch-mode power supply section right of line A-B has in common the switch 110, control 109 and feedback 125 with the power factor correction front-end left of line A-B. This new technique uses far few components than current designs, which results in a smaller, lower cost and simpler design.

The power supply receives an ac input signal at 100 which then goes through a noise filter 101 which attenuates the noise generated by switch 110 below a predetermined level. The signal then goes to an ac rectifier 102 where it is converted to a pulsating dc 103. The pulsating dc 103 is applied to capacitor 104, which is used to reduce the switching noise of switch 110, it does not act as a bulk hold-up capacitor and does not smooth the pulsating dc 103. The pulsating dc 103 is then applied across the primary winding 106 of a fly-back transformer, diode 112 and switch 110. Diodes 112 and 113 block the fly-back voltage that will occur when primary 106 and primary 121 fly-back when switch 110 opens. These diodes 112, 113 isolate the two primary windings 106 and 121 from each other when switch 110 opens. The voltage across switch 110 will be the greater of the fly-back voltage of primary 106 or

121. When switch 110 is closed the pulsating dc 103 flows into primary winding 106. When the switch 110 opens this energy is then transferred to secondary winding 107 which is rectified by diode 108 and stored as a dc voltage across capacitor 119 which is a hold-up capacitor. Hold-up capacitor 119 provides power to primary 121 when the pulsating dc 103 approaches a minimum as the power delivered by secondary winding 107 would be also a minimum. The power delivered by secondary 107 behaves the same as in figures 1. This output power delivered by secondary winding 107 is a function of the pulsating dc 103.

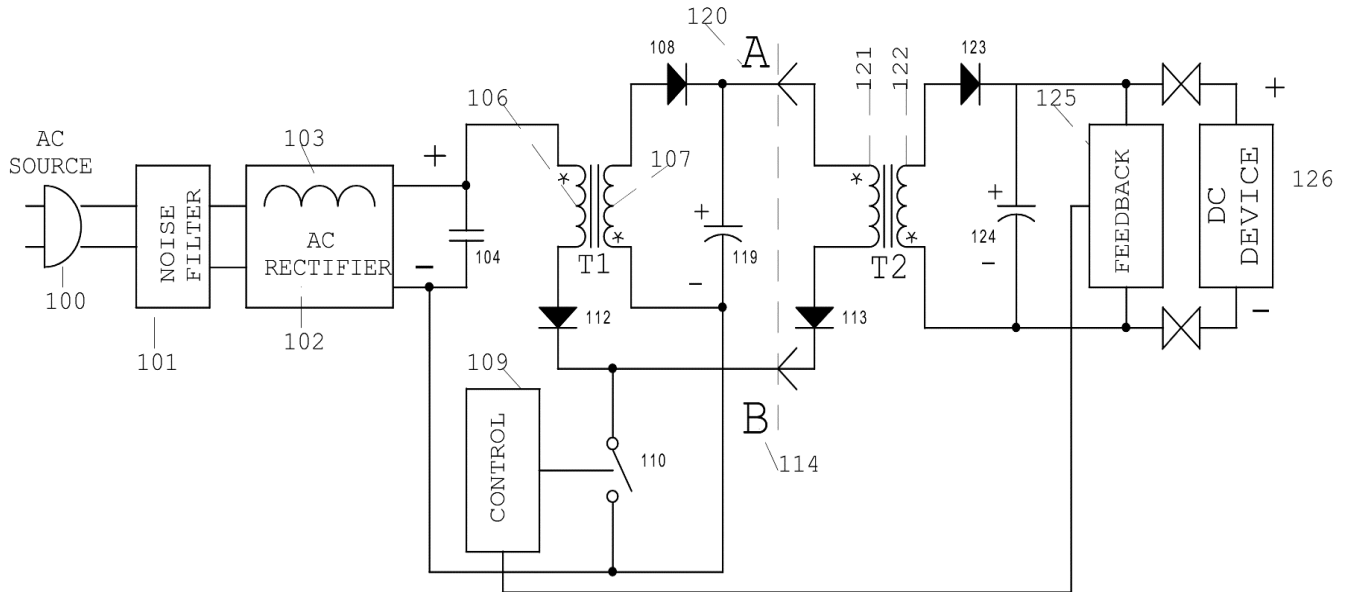

FIGURE 2

The voltage present across capacitor 119 is applied to the primary winding 121, diode 113, then switch 110 and returns to capacitor 119. When switch 110 closes current from C119 flows into the primary winding 121 storing energy. When switch 110 opens this energy stored in the primary winding 121 is then transferred to the secondary winding 122 then through diode 123 to capacitor 124, feedback 125 and the dc devices 126 that are being operated by the power supply. With the voltage across hold-up capacitor 119 constant in value the power transferred through primary winding 121 and secondary winding 122 to capacitor 124 is constant with low ripple. The fast feedback 125 then adjusts the Ton to regulate the output, correcting for variances in the ac input 100 and the power drawn by the dc devices 126 . Multiple secondaries with separate isolated voltage outputs are possible but only one secondary is shown for simplicity.

Switch 110 then does two jobs, it controls the amount of power transferred to capacitor 119 from the pulsating dc 103 and it transfers the energy stored in capacitor 119 to the output capacitor 124 and the dc devices 126. The feedback circuit 125 is fast typically a few kHz, much faster than the feedback used in figure 1. The advantage of this is that a well regulated, low ripple voltage output across dc device 126 is created.

Switch 110 maintains nearly a constant  $T_{on}$  and is changed by the feedback 125, which provides a signal to the control 109 maintaining a well-regulated output. The feedback 125 in this case operates fast such that a high quality regulated output is generated. As the dc devices 126 demand more power the feedback will tell the control to increase the  $T_{on}$  of switch 110. The increased  $T_{on}$  will transfer more power through primary winding 106 from the pulsating dc 103 to hold-up capacitor 119. The increased  $T_{on}$  will also cause an increase in the power transferred from the hold-up capacitor 119 through primary winding 121 to secondary winding 122 then output filter capacitor 124. This power is then available to the dc devices 126 as required. With both transformers T1 and T2 being fly-back in design the relationship of power transferred is the same relative to  $T_{on}$ . This creates a simple to control power supply with power factor and well regulated using just a single switch.

Other switch-mode topologies can be substituted on the right side of the line A-B in place of T2, as well as paralleling multiple circuits for higher power output.

## **Test Results From Working Proto-types**

The following pages present the test results of two working proto-types that demonstrate the techniques presented in figures 1 and 2. These proto-types were made by modifying an off the shelf fly-back power supply. The first section gives the schematic and test results of the purchased power supply, prior to modification. The second section presents the schematic and test results of the power supply after it was modified to demonstrate the principals of figure 1. The final section is a schematic of the power supply and test results after it was modified to demonstrate the principals of figure 2.

### **Standard Fly-back Power Supply**

This section presents sample plots of current and voltage measurements of an off the shelf 30W, 5V/6A fly-back power supply. The design is typical with universal input capability. The first schematic is titled "FLY-BACK, PRIOR ART". The power supply is shown in its original form prior to modification and it utilizes the low cost UC3844 current mode power supply integrated circuit for control. It will operate from a 90-250 Vac 47-63Hz voltage source.

Various plots, following the schematic, were made of its input current versus line voltage. These plots were made at three different load conditions namely, no load (16 ohm internal load resistance), 6.25W a 4 ohm load, and 25W using a 1 ohm load. Little to no correction has been made for power factor and the current is a short pulse at high line. The current was measured using a 1 ohm resistor in series the neutral line of the power supply.



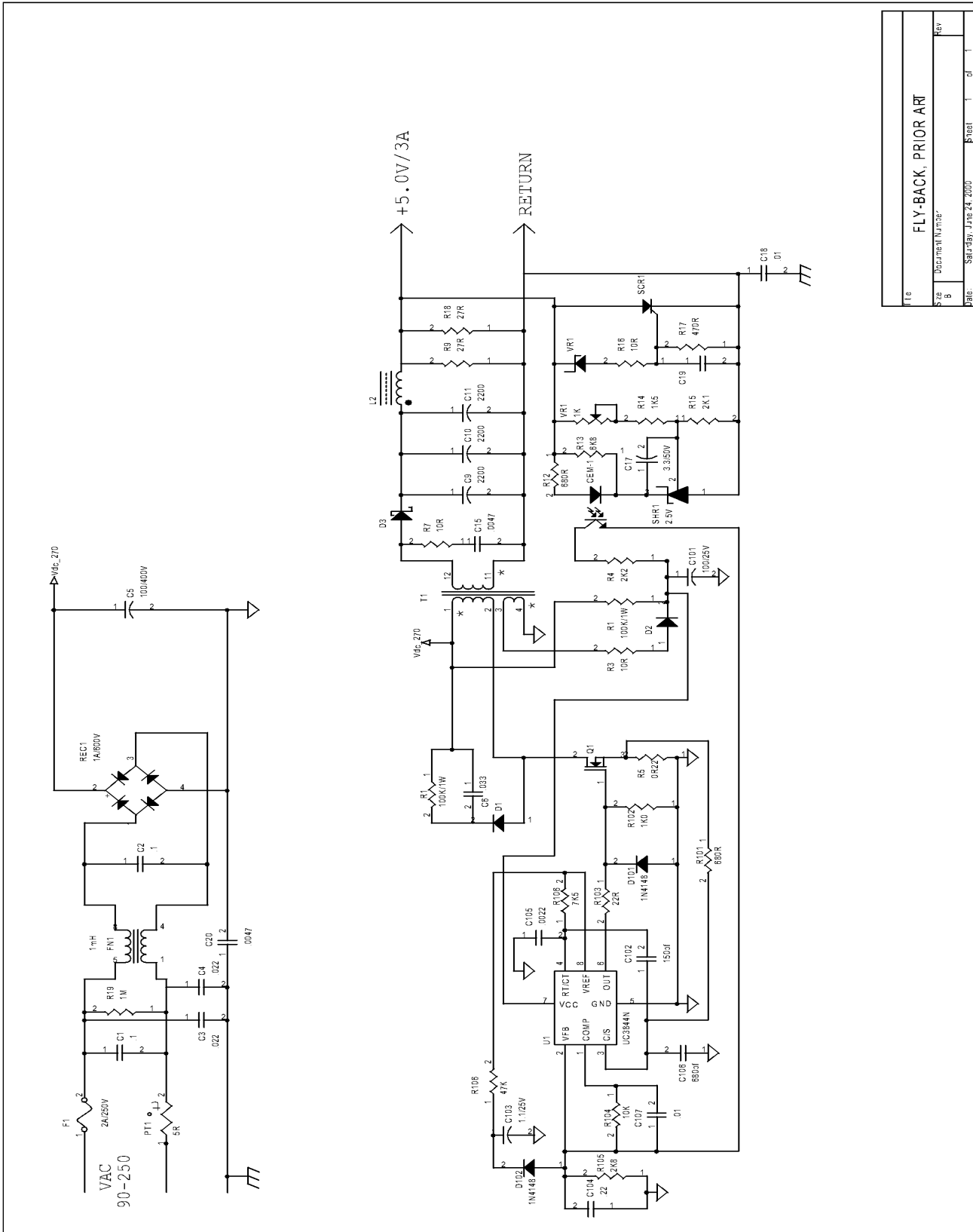

Title		FLY-BACK, PRIOR ART	
Size	Document Number		REV
Part	SBL237, LRS 24, 2000	Page	1 of 1

For all plots channel 2, the lower in amplitude, is current where 1Volt= 1 Amp. and channel 1 is line voltage, 50 volt per division. Averaging of 16 times is used to improve the sharpness of the line harmonics.

Plot 1 is no load, just the 16 ohm resistance inside the power supply. The smaller waveform is the current. Plot 2 @ 6.25W a 4 ohm load, plot 3 @ 25W a 1 ohm. Plot 4 is the output ripple of the power supply @ 25W using a 1 ohm load.

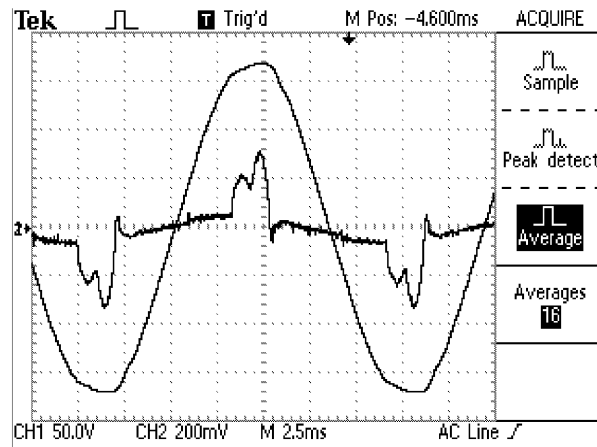

PLOT 1 No Load

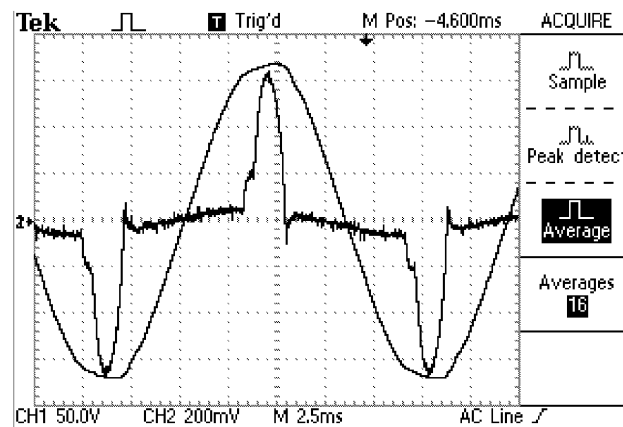

PLOT 2 @6.25W

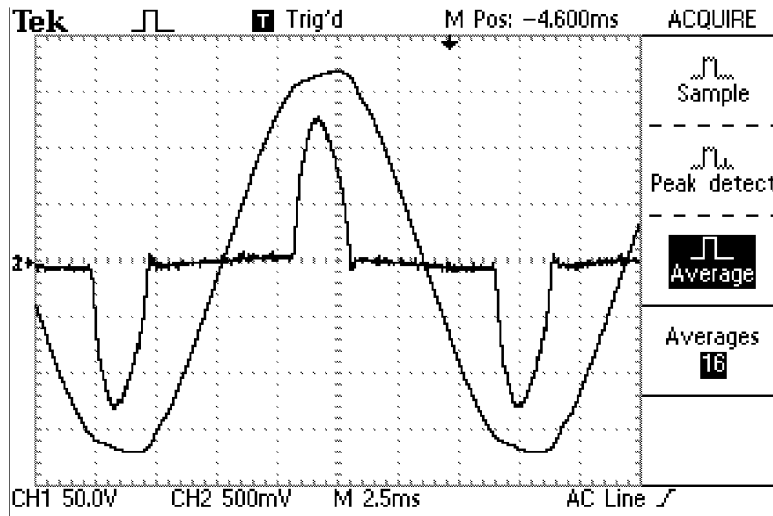

PLOT 3 @25W

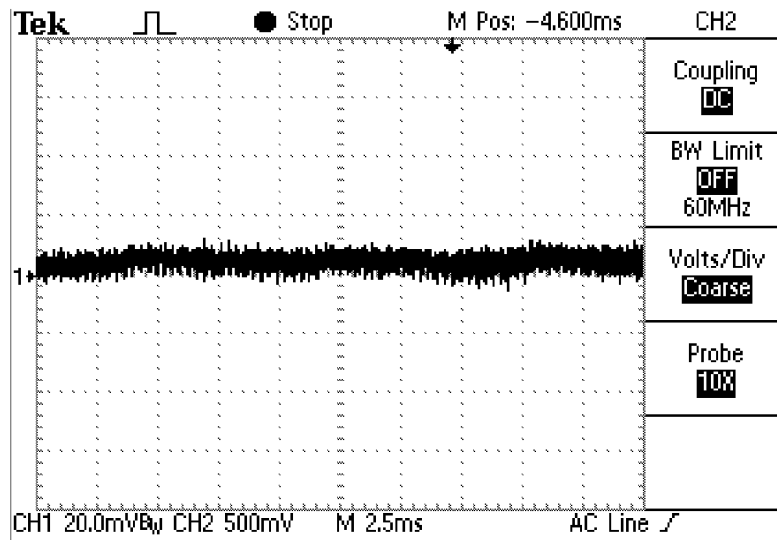

PLOT 4 Output Ripple @25W

## **Fly-back PFC With Isolated Output**

The following section demonstrates the principals of the new art as shown in Figure 1. Sample plots of current and voltage measurements of a modified off the shelf 30W, 5V/6A fly-back power supply have been provided. The modifications change the standard power supply in such a way that its input has a high degree of power factor correction. The output does not have a high degree of regulation, it would be best to describe it as a well regulated rectified AC transformer output. The schematic showing the changes follows and is titled "FLY-BACK, PFC WITH ISOLATED OUTPUT". The design has preserved the universal input capability of the original power supply. The power supply should still be capable of operating from a 90-250 Vac 47-63Hz or suitable DC voltage source. Operating from a 400Hz Military AC power source should be possible with minor modifications.

The modifications that were made consist of removing the bulk hold-up capacitor C5 and replacing it with a 1mH inductor labeled L-NEW and a small film .27mmF film capacitor labeled C-NEW. Other changes altered the UC3844 control integrated circuit from current mode operation to voltage mode. This was accomplished by adding one diode and two additional resistors shown near the UC3844 integrated circuit. These parts have circuit reference called D-NEW or R-NEW. Inserting a diode in series with R101 preserved the over current protection. This extra diode drop ensures that no current feedback will occur unless the current through Q1 is excessive. On the secondary side of T1 two of the output filter capacitors, C10 and C11 were increased in size to reduce line ripple in the output. The feedback circuit associated with SHR1, the 2.5 volt reference has been modified to give a quick response to large output voltage changes but only a slow response to small changes, reducing the amount of 2<sup>nd</sup> harmonic line current generated by the fly-back switcher. This design has a huge range of uses such as battery chargers, AC adapter, power supply in a consumer electronics, laser printer, photocopier, TV etc. In these applications a well-regulated voltage can be achieved using a three terminal regulator while the power to operate a motor etc. need not be low ripple. Many logic applications using CMOS logic can easily tolerate the small amount of ripple present on the output of this power supply.

Various plots, following the schematic, were made of its input current versus line voltage. Channel 1 is the line voltage and channel 2, the lower in amplitude, is line current where 1Volt= 1 Amp. These plots were made at three different load conditions namely. Plot 5 @ no load (16 ohm internal load resistance), Plot 6 @ 6.25W a 4 ohm load, and Plot 7 @ 25W using a 1 ohm load. For plots 8 through 10, channel 1 is the displayed waveform and channel 2 is not used. Plot 8 is the output ripple voltage @ no load (16 ohm internal load resistance). Plot 9 is the ripple @ 6.25W a 4 ohm load and Plot 10 is the ripple @ 25W using a 1 ohm load.

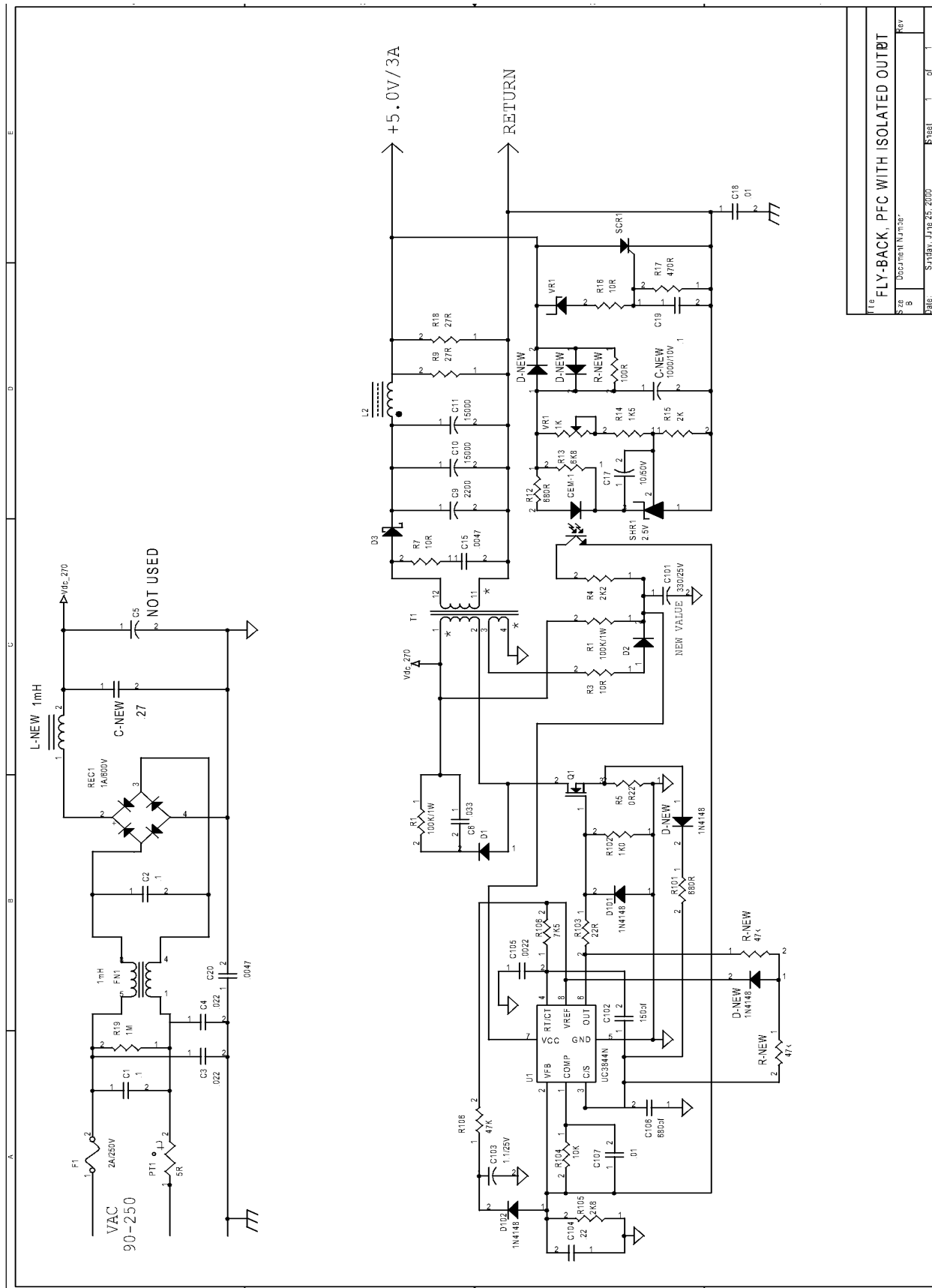

Title		FLY-BACK, PFC WITH ISOLATED OUTPUT	
Sheet	5	Document Number	83V
Date	5/19/97, 1/25/2000	Sheet	1 of 1

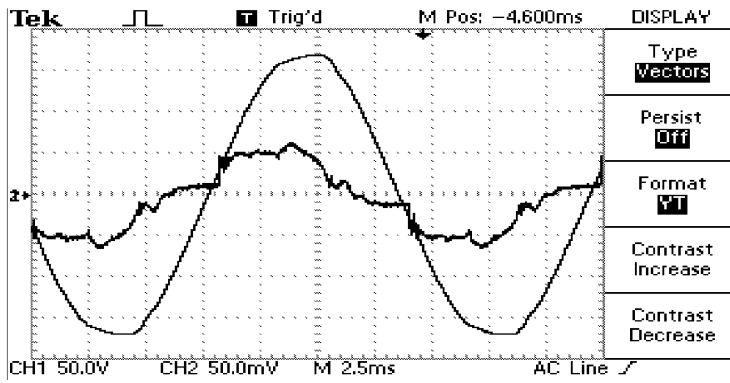

PLOT 5 No Load, inner waveform is current

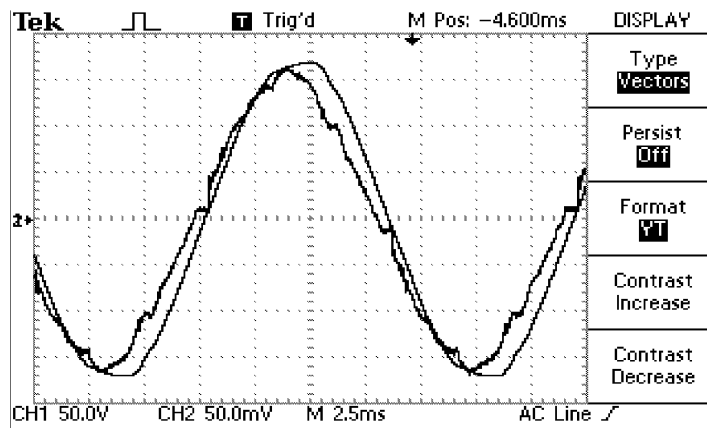

PLOT 6 @6.25W, inner waveform is current

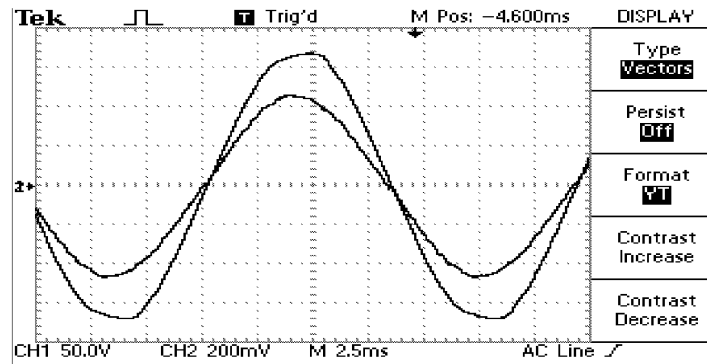

PLOT 7 @25W, inner waveform is current

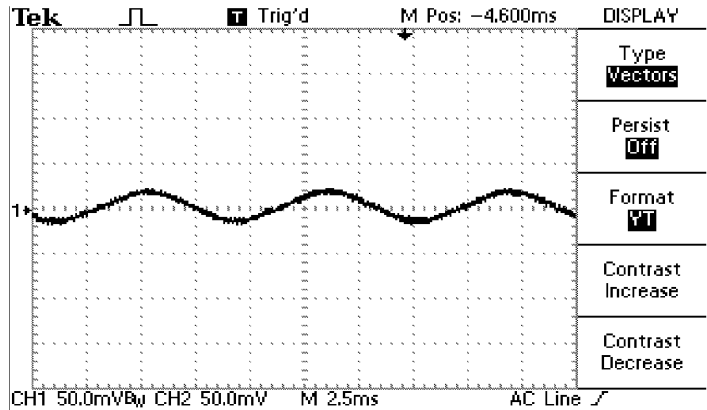

PLOT 8 Output Ripple No Load, 50mV/Div

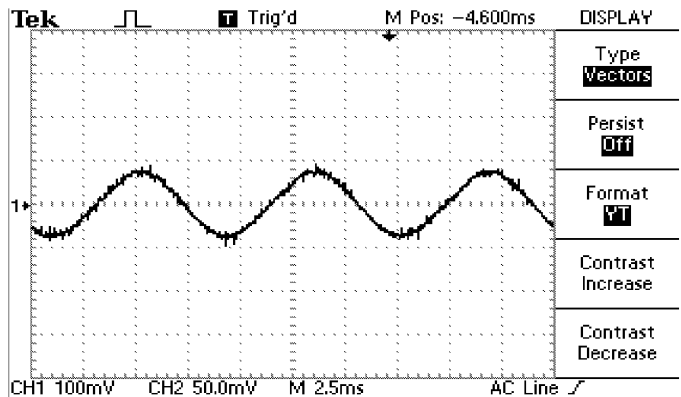

PLOT 9 Output Ripple @6.25W, 100mV/Div

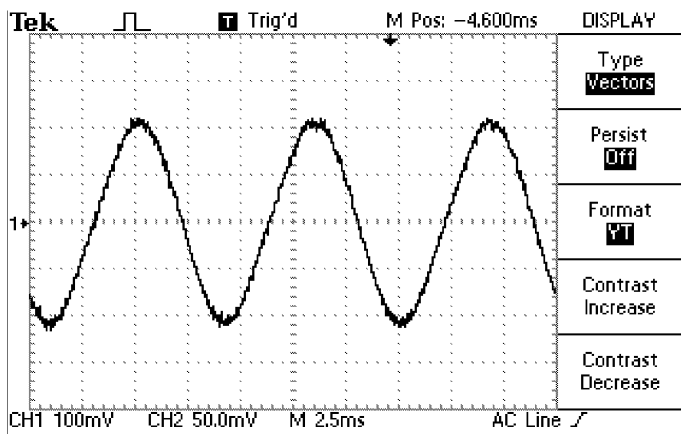

PLOT 10 Output Ripple @25W(5V@5A), 100mV/Div

## **Fly-back, Single Switch With PFC**

The following section demonstrates the principals of the new art as shown in Figure 2. A schematic as well as sample plots of current and voltage measurements of a modified off the shelf 30W, 5V/6A fly-back power supply are provided. The modifications change the standard power supply in such a way that its' input has a high degree of power factor correction while maintaining a low ripple regulated output. The output regulation is not changed from the original power supply. NO changes were made to the feedback or output filter. The only change made was the insertion of three diodes, a capacitor, inductor and transformer. These added parts are clearly indicated by a bordered area with labels L\_NEW, C\_NEW, T-NEW and D-NEW. For most applications T\_NEW should have .707 times the input inductance of T1. The UC3844 control integrated circuit has no changes and is still operated in current mode. The schematic showing these alterations follow and is titled "FLY-BACK, SINGLE SWITCH WITH PFC". The design has preserved the universal input capability of the original power supply, operating from a 90-250 Vac 47-63Hz or suitable DC voltage source. Operating from a 400Hz Military AC power source should be possible with minor modifications. This design can be used anywhere that a fly-back power supply design is suitable. This applies to most consumer electronic applications as well as lower power industrial applications.

Various plots, following the schematic, were made of its input current versus line voltage. Channel 1 is the line voltage and channel 2, the lower in amplitude, is line current where 1Volt= 1 Amp. These plots were made at three different load conditions namely, Plot 11 @ no load (16 ohm internal load resistance), Plot 12 @ 6.25W a 4 ohm load, and Plot 13 @ 25W using a 1 ohm load. Plot 14 is the out put ripple @ 25W using a 1 ohm load.

### **Special Merits**

This technique of power factor correction is much less complicated than more traditional methods. A special control loop for the PFC is not required and actually doesn't exist. The PFC tracks almost perfectly the demand of the output load with minimal over-shoot or delay. For the example just presented no adjustments to the original control loop were required.

Under some circumstances it is possible for the input current to follow the fundamental input sine wave input, providing a purer sine load to the input mains, attenuating the effect of line disturbances. Some of the following plots with corrected input current shows to a small degree this effect at full load. For example PLOT 13 shows the effect slightly as the current waveform appears to be less distorted than the AC line voltage. Another major improvement is that the input PFC attenuates AC input voltage steps placing lower demand on the feedback and control loops.



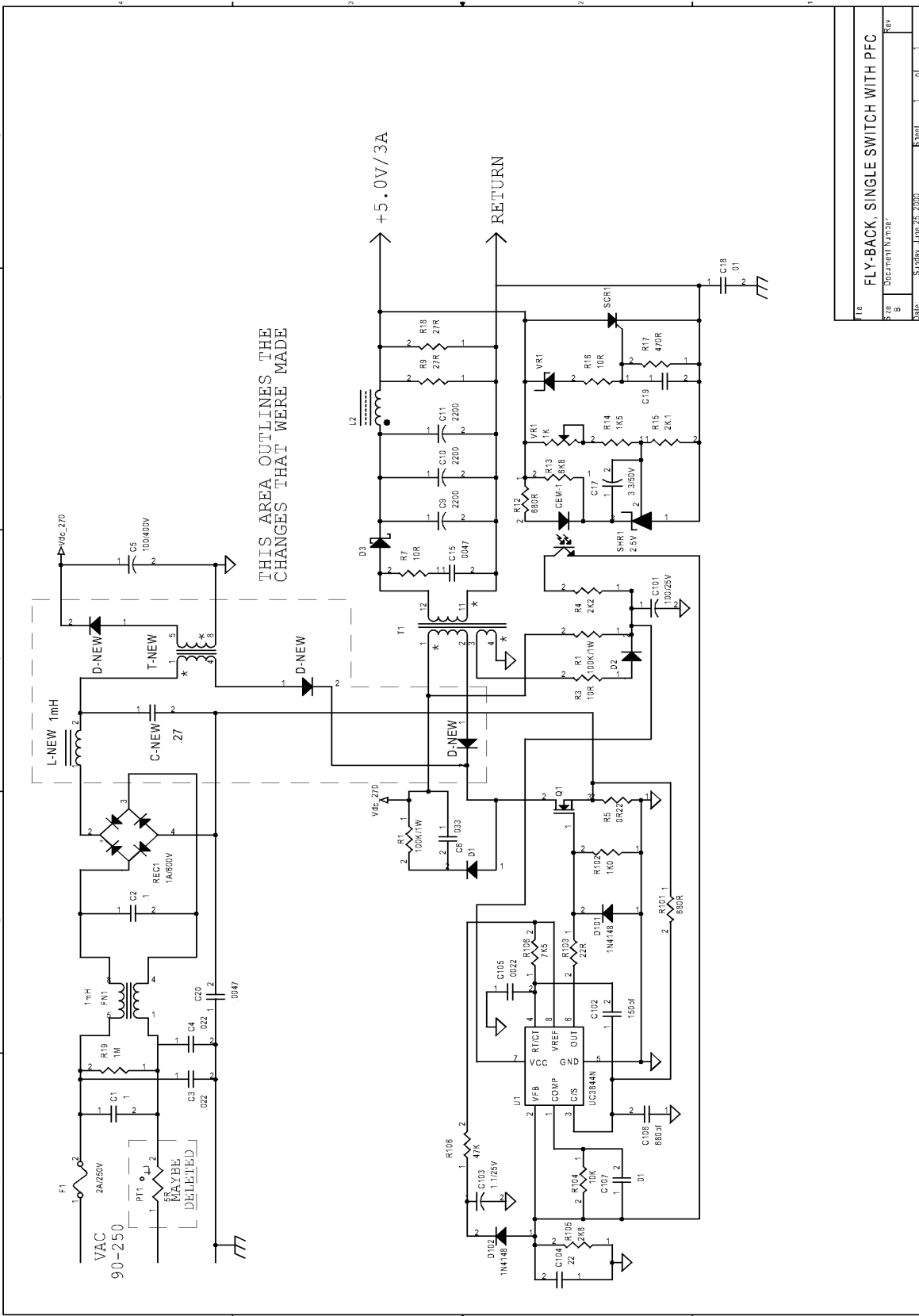

FLY-BACK, SINGLE SWITCH WITH PFC

Document Number: 9248 9

Date: 1/24/2000

Page: 1 of 1

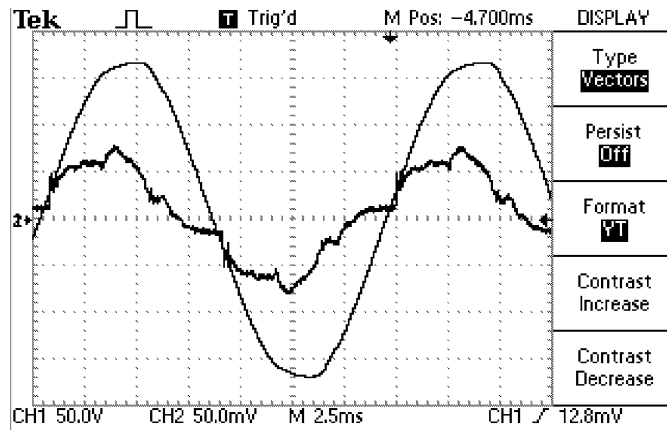

PLOT 11 No Load, inner waveform is current

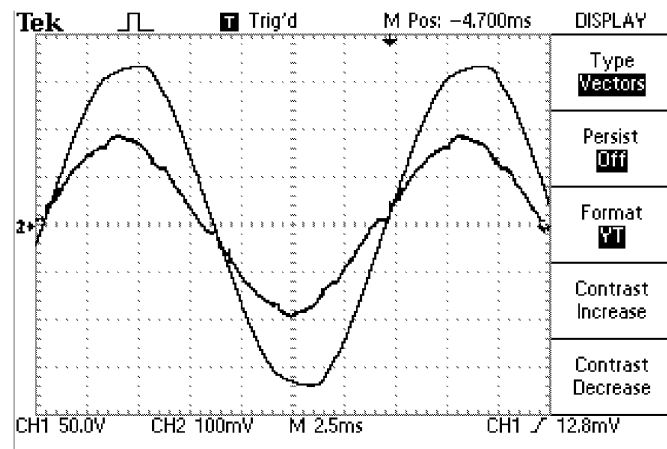

PLOT 12 @6.25W, inner waveform is current

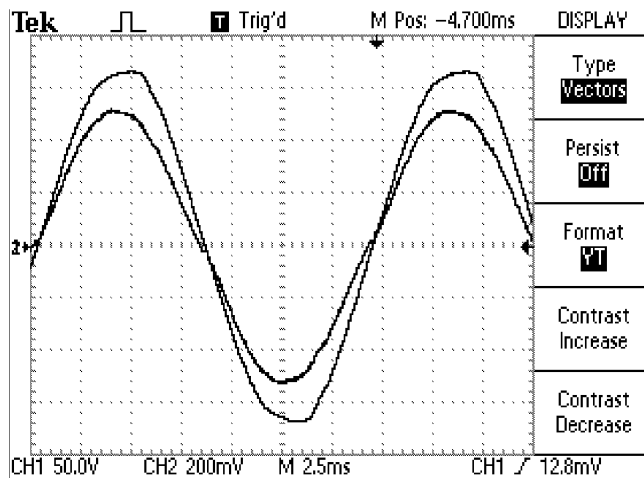

PLOT 13 @25W, inner waveform is current

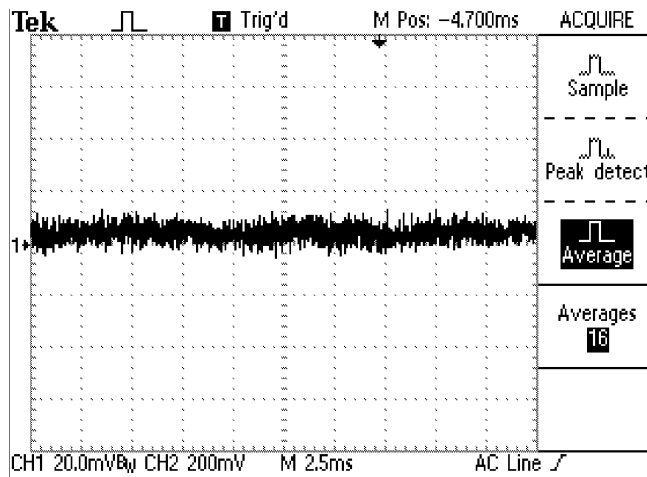

PLOT 14 Output Ripple @25W, (5V@5A), CH1 20mv/div

### Additional Information

Additional information as well as a working model is available of both of the technologies, upon special request. For those who wish for themselves to try the new technology it is recommend to start with the first example before proceeding with the second well regulated PFC circuit. I found that the second design works best if T-NEW input inductance is about .707 of the T1 input inductance as well as adjust the primary and secondary ratio of T-NEW to prevent saturation and to ensure discontinuous operation through the complete pulsating DC cycle. For the second example the current carrying capacity of Q1 may have to be increased and for some designs changes to the snubbing circuit maybe required.

## **Invitation for Proposals to License**

At this time invitations are being considered for license either exclusive or otherwise.

## **Brief Biography of the Inventor**

The inventor graduated from the University of Waterloo in 1980 with a B.Sc. in Honors Physics. His principal area of expertise is electronics and solid-state physics.

His work history covers 20 years in the electronics industry often in cutting edge technologies. For the past twelve years he has been involved in the development of specialty power supplies used for power microwave transmitters used in various radar and communication research programs around the world.

## **Inquiries**

Additional technical information and special technical consultation is available as are working power supplies, demonstrating the discussed technology.

e-mail: [davidk@stonepathelectronics](mailto:davidk@stonepathelectronics)  
or [vagary@sympatico.ca](mailto:vagary@sympatico.ca)

**USE as current [dave.k@stonepathpower.com](mailto:dave.k@stonepathpower.com) (16 April 2008)**  
**See [www.stonepathpower.com](http://www.stonepathpower.com) for contact information**

cell phone: (416)-459-8643  
phone: (905)-831-8091 (messages)

mail: Mr. David Kelly  
Stonepath Electronics  
733 Stonepath Circle,  
Pickering, Ontario,  
Canada  
L1V 3S9